



www.sherpa-project.eu

Application of SHERPA aerial robots to inspection (not maintenance!)

Lorenzo Marconi
CASY-DEI University of Bologna



Search and rescue in unfriendly and possibly hostile environments, like the ones in which civil protection, alpine rescuers and forest guards usually operate

ROBUSTNESS!!!

Features:

- Unstructured environments
- Severe operative conditions (weather, terrain,..)
- Presence of human (rescuer) often “focused” on demanding tasks
- Team (Human & Machine) capabilities
- Emotional aspects

“The Wasp”



“Trained wasp” by ASLATECH



Function	Specifications
Fly very close to the ground to allow a more precise detection of the human position behind the snow	Approximately 20-30 cm
Long flight endurance to support typical winter scenario operations	Approximately 20 minutes of continuous flight operations
Robustness to medium disturbances	20 km/h
Weight low enough to allow being carried by skiers	2 kg
Foldability to allow storage in backpack for skiers	Storage in backpack
Robustness to low temperatures	-10 °C
Robustness to rain or snow falls	Capability to operate with high level of humidity
Fly at the high absolute altitudes in mountains	3000 – 3500m a.s.l.
Waypoint navigation and fly autonomously along a pre-specified path	Trajectory tracking error < 3 m in all weather conditions



Quick localization in avalanche scenarios (Highest TRL)



Giorgio Viana, CAI, Alpine rescuer

“Intelligent donkey with SHERPA BOX

WORKING IN TEAM with the GROUND VEHICLE

- **Ground rover:** “intelligent” carrying vehicle equipped with a multi-functional robotic arm
- Automatic battery change x8

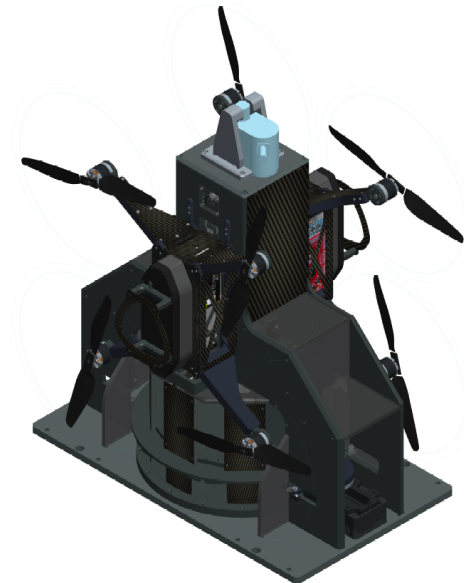
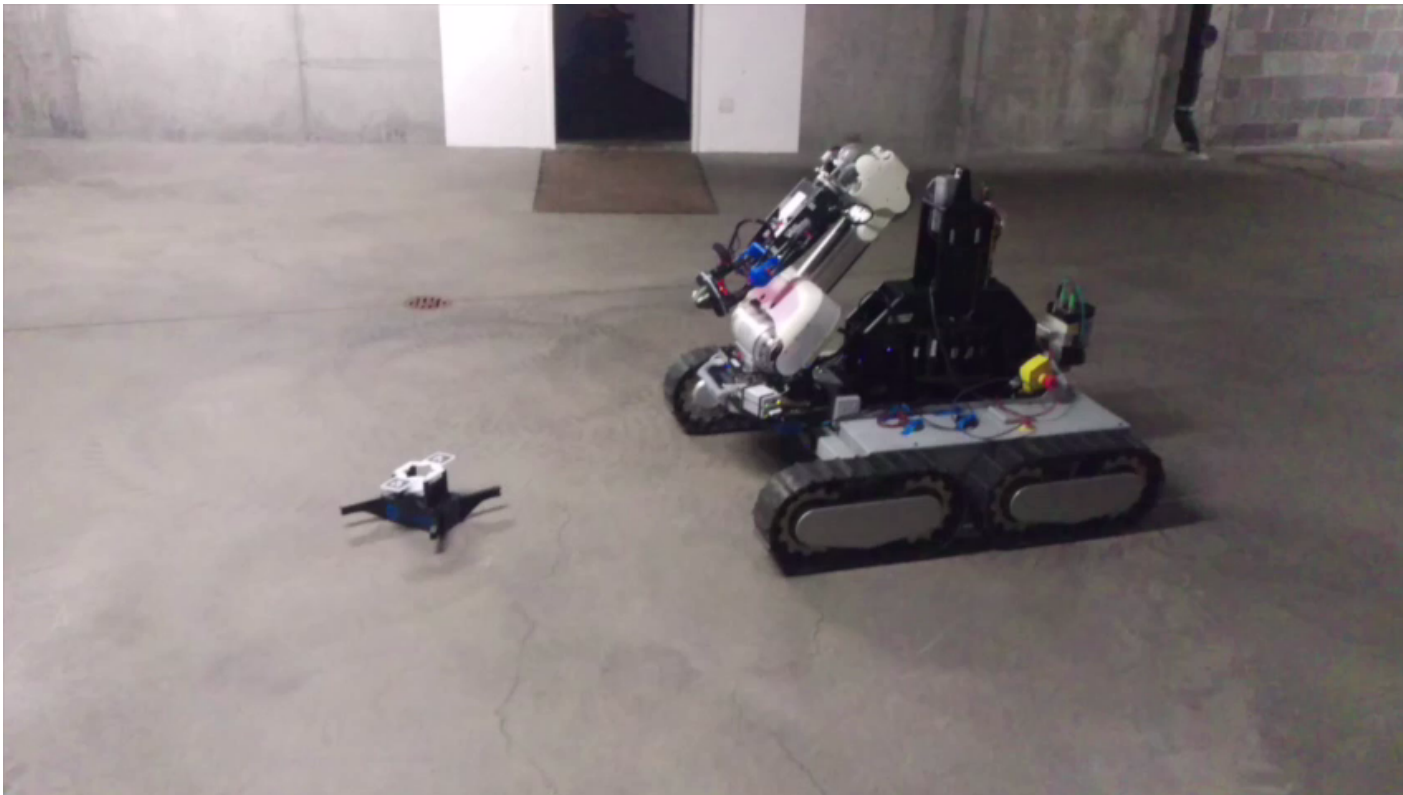

“Patrolling hawks”



- **High-altitude, High-Payload unmanned aerial vehicles**, patrolling a large area at high-altitude (50-100m) and complementing the capabilities of the small-scale UAVs.
- Constructing rough 3D maps of the rescuing area, serving as a communication hub.
- Fixed-wing, Rmax (ETHZ, Linkoping)